

DOOR LOCKS – 2007-2009 KIA AMANTI

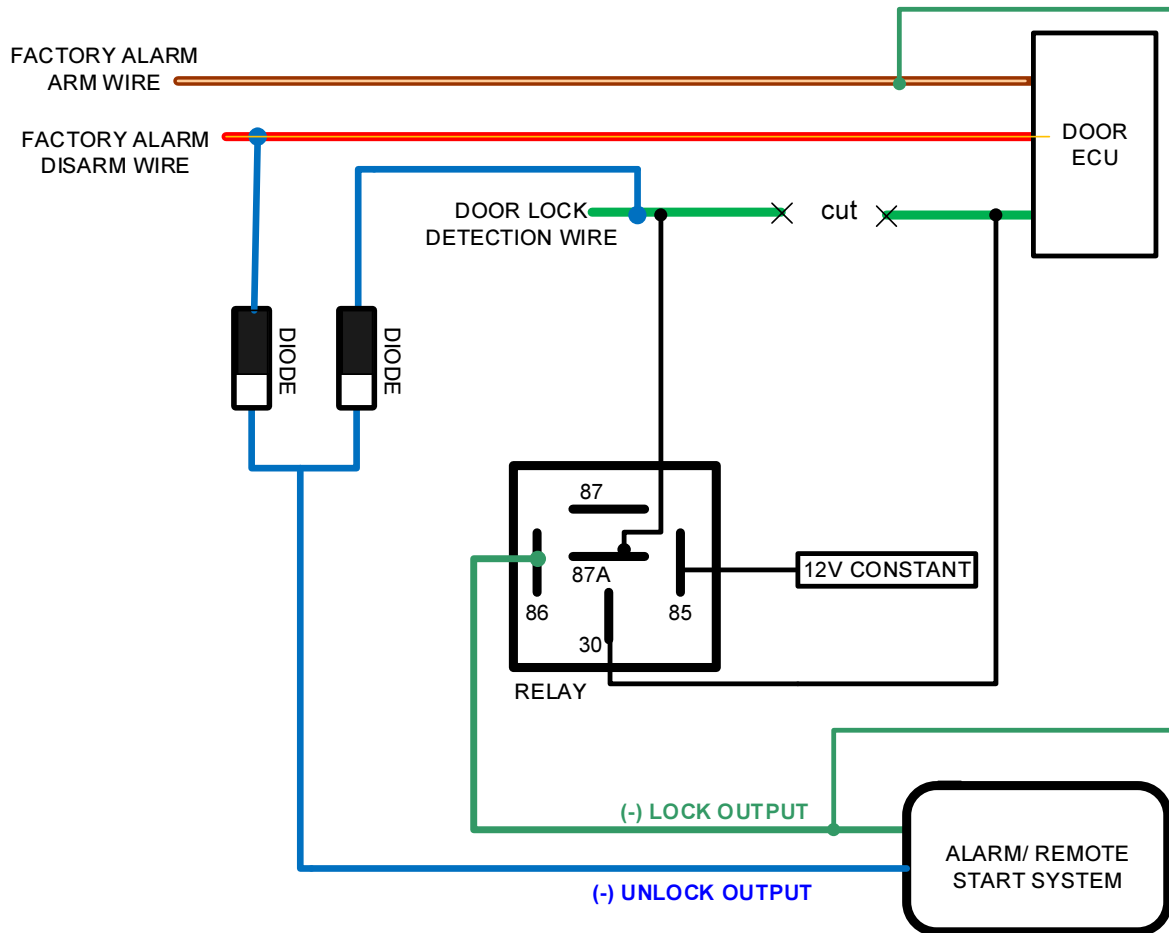

RELAY

PIN	CONNECTION
85	TO 12V CONSTANT
86	TO (-) LOCK OUTPUT FROM ALARM/REMOTE START SYSTEM
87	NO CONNECTION
87A	TO GREEN DOOR LOCK DETECTION WIRE – DOOR KEY CYLINDER SIDE
30	TO GREEN DOOR LOCK DETECTION WIRE – POWER WINDOW SWITCH MODULE

Remote starter and security installations should be attempted by experienced security installers only. Information contained is accurate to the best of our knowledge and experience. Information contained is without any representation of warranty. It is the installer's responsibility to test and confirm all circuits with a digital multi-meter. Proper installation remains the responsibility of the installer. CarInstallExperts.com assumes no liability or responsibility resulting from an improper installation, even in reliance with the information contained in this guide.